



# MCBOX

## FEATURES

- ACCESS CONTROL
- SUITABLE FOR ANY PUMP
- PULSE METER INPUT
- EASY TO INSTALL
- MULTI USERS
- COMPATIBLE WITH SSM AGILIS SOFTWARE

The PIUSI MCBOX is a practical electronic multi-user control panel that allows to manage and control an existing pump, pulse meter and nozzle. Integrated with the SELF SERVICE MANAGEMENT AGILIS, it grants the possibility to download all the transactions.

### PERFORMANCE

UP TO  
**250**

USERS

**AC/DC**  
VOLTAGE

POWER



MCBOX



### PACKAGING

CODE	WEIGHT		PACKAGING		
	KG	LBS	MM	INCH	PCS/BOX
F1398000D	5	11	300X300X180	11,8X11,8X7	1
F1398005C	5	11	300X300X180	11,8X11,8X7	1
F13980130	5	11	300X300X180	11,8X11,8X7	1



FILTRATION



TANK MONITORING



HOSE REEL



ACCESSORIES



MERCHANDISE



ANY BIODIESEL



AIR



ANTIFREEZE



AdBlue®



BIODIESEL



DIESEL



FOOD



GASOLINE



GREASE



KEROSENE



OIL



WATER



WINDSCREEN

## CONNECTION SCHEME



PUMP CONTROL



PULSE METER INPUT



TANK LEVEL INDICATOR



NOZZLE SWITCH WITH A60



## IN THE BOX

- MCBOX UNIT
- INSTRUCTION MANUAL

## DETAILS



SHUTTER



SSM AGILIS SOFTWARE



EASY ACCESS TO CONNECTION

## DIMENSIONS

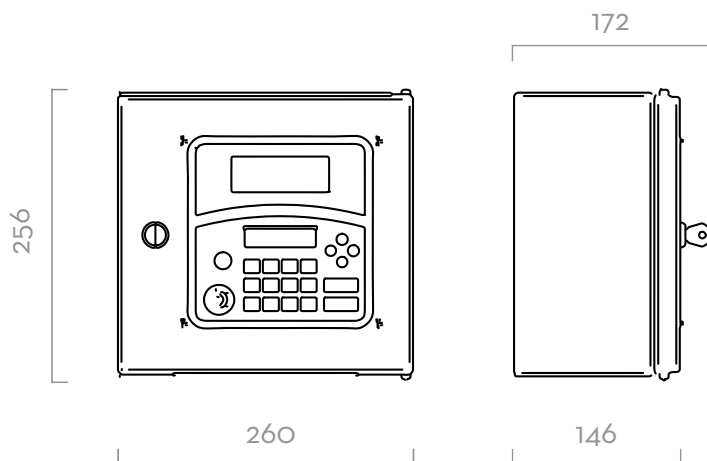

Dimensions expressed in millimeters

## TECHNICAL DATA

CODE	DESCRIPTION	FLUIDS TYPE	USERS	VOLTAGE			SSM AGILIS SOFTWARE
				AC V./HZ	POWER WATT	AMP. MAX. (load motor)	
F139800OD	MCBOX 100-240V 80U AGILIS	A Ad B D F G G K O W W	250	100/240	5	15	OPTIONAL
F1398005C	MCBOX 100-240V 250U AGILIS	A Ad B D F G G K O W W	80	100/240	5	15	OPTIONAL
F13980130	MCBOX 12V/24V 250U AGILIS	A Ad B D F G G K O W W	250	12/24	5	50/25	OPTIONAL